

The Complete CAM Solution,
with revolutionary iMachining,
fully Integrated in SOLIDWORKS®

SolidCAM

The Leaders in Integrated CAM

- iMachining 2D and 3D
- 2.5D Milling
- HSS – 3D High Speed Surface Machining
- HSR & HSM – 3D Roughing & Machining
- Indexial Multi-Axis Milling
- Simultaneous 5x Milling
- Turning and Advanced Mill-Turn
- Multi-Channel Synchronization
- Swiss-Type & Sliding Headstock CNCs
- Solid Probe – Probing & Measuring

The unique, revolutionary Milling Technology



iMachining®
patent by SolidCAM

TIME SAVINGS
70%
... AND MORE!



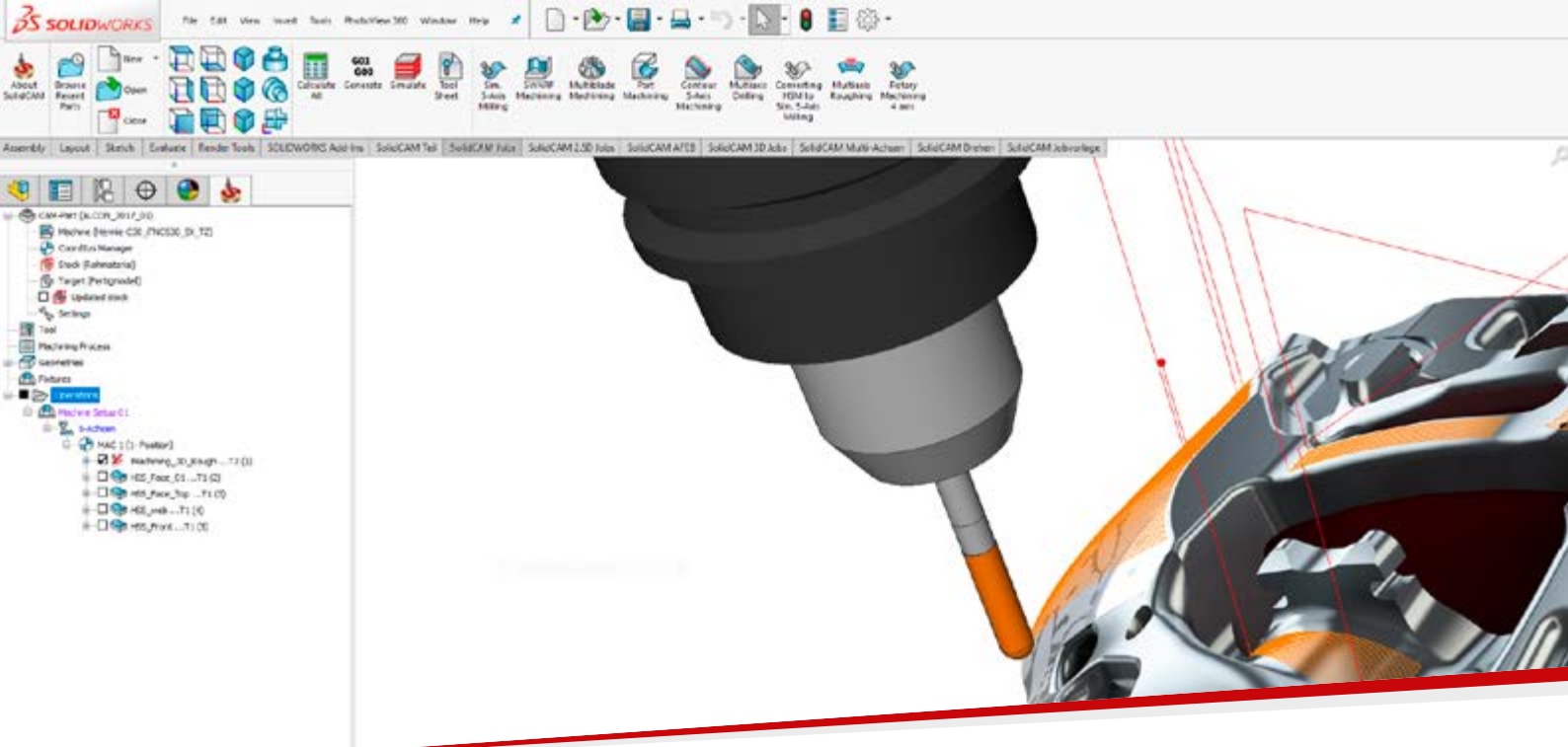

SolidCAM is the Complete, ‘Best-in-Class’ CAM Suite for Profitable CNC-Programming in SOLIDWORKS

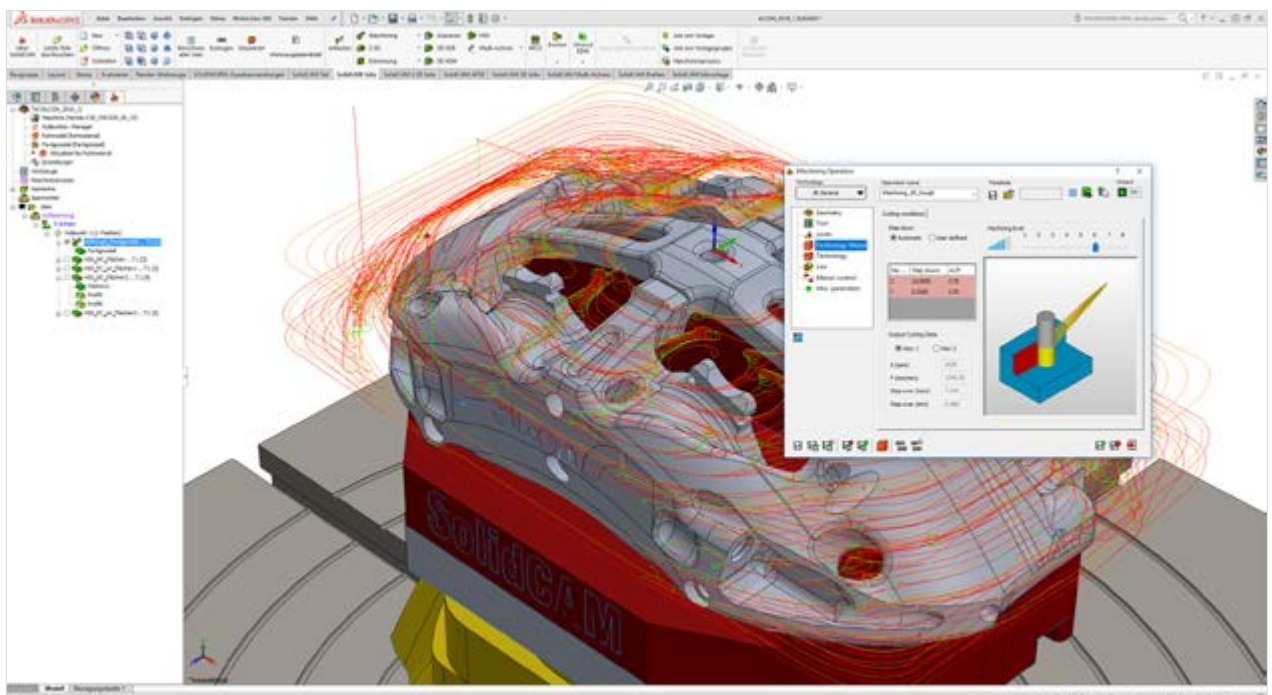

Major Benefits of Using SolidCAM in SOLIDWORKS:

- SOLIDWORKS look and feel through seamless single window integration – with full support for modern 4K displays
- Full associativity: toolpaths automatically update when the SOLIDWORKS model changes
- SolidCAM works in the SOLIDWORKS assembly mode to define fixtures, tooling and vices
- SolidCAM + SOLIDWORKS is scalable with packages for all CNC machine types and applications. The integrated CAD/CAM-Solution SOLIDWORKS + SolidCAM is available at a competitive bundle-price

SolidCAM, including the revolutionary iMachining, is seamlessly integrated in SOLIDWORKS, with full tool-path associativity to the SOLIDWORKS model. With the single-window integration in SOLIDWORKS, all machining operations can be defined, calculated and verified without leaving the parametric SOLIDWORKS assembly environment.

All 2D and 3D geometries used for machining are fully associative to the SOLIDWORKS design model. If you make any changes to your SOLIDWORKS model, all of your CAM operations will be automatically updated.

SolidCAM – The Leading Integrated CAM Solution in SOLIDWORKS

CERTIFIED
Gold
Product

 SOLIDWORKS

Customers rave about SolidCAM integrated in SOLIDWORKS

- ” This approach shortens the learning curve for programmers, offers greater geometry editing and manipulation power to manufacturing and provides a common tool for supporting interaction between designers and machinists.”
- ” The integrated approach facilitates discussion and resolution of manufacturing issues because everyone is working with the same model and the same modeler. We communicate issues and features a lot better working with an integrated system.”
- ” If changes are made on the manufacturing side, we capture them on both the design side and the manufacturing side because SOLIDWORKS and SolidCAM are fully associative.”
- ” The integrated approach has a lot of advantages, including saving time, accessing a single geometry file, and using the intelligence of our design data in a more efficient, systematic way.”
- ” SolidCAM is the Swiss pocket knife for machining. With the modules for the 2.5D, 3D, simultaneous 5-axis machining and rotary milling, all daily machining tasks can be done quickly – from the complex drilling pattern to the most demanding 5-axis impeller. Program the part, simulate and off you go on the machine. The software delivers, what it has promised!”

You Never Have to Leave the SOLIDWORKS Window!

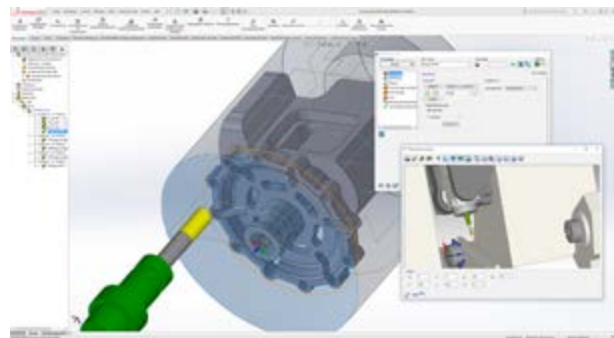

- ” Since loading the SolidCAM trial version integrated in SOLIDWORKS, I’ve been able to program complex parts and run them without concern. The machine seems to run smoother than before, cutters last longer and confidence levels are high. I am able to train others here to use SolidCAM with ease. The software is pretty self-explanatory and the tutorials are easy to follow.”
- ” The tight integration with SOLIDWORKS makes my design-to-production life cycle easy and fast. The SolidCAM support team is rock solid. I do some pretty complex 4-axis production projects and SolidCAM handles them very nicely.”

iMachining 2D

Imagine putting the Knowledge and Experience of Hundreds of CAM and CNC Masters in the Palm of Your Hand – Experience iMachining’s Wizard & Toolpath!

Patented iMachining: “Truly Amazing”

This is what customers, machine tool manufacturers and tooling companies alike say about iMachining. The revolutionary iMachining CAM module, fully integrated in SOLIDWORKS, will make you and your CNC machines more profitable and more competitive than ever before.

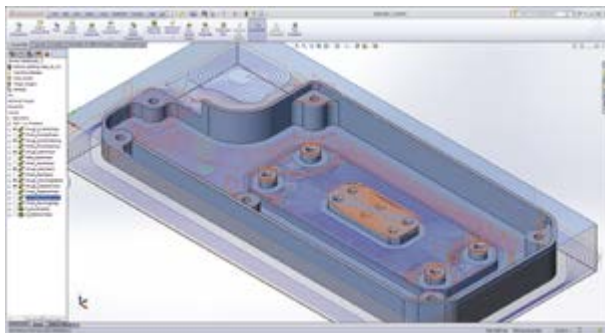

The Revolution in CNC Machining

- + Increased Productivity due to shorter cycles – time savings 70% and more!
- + Dramatically Increased tool life
- + Unmatched hard material machining
- + Outstanding small tool performance
- + 4-axis and Mill-Turn iMachining
- + Automatic, optimal feeds and speeds
- + High programming productivity
- + Shortest learning curve in the Industry

Unique Technology Wizard

SolidCAM’s iMachining has the exclusive patented iMachining Technology Wizard, the industry’s first and only Wizard that automatically calculates the Cutting conditions for the iMachining tool path.

The unique Technology Wizard provides optimal feeds and speeds, taking into account the toolpath, stock and tool material as well as machine specifications.

All SolidCAM customers worldwide, who bought iMachining, are enjoying immense savings and have gained a real competitive advantage.

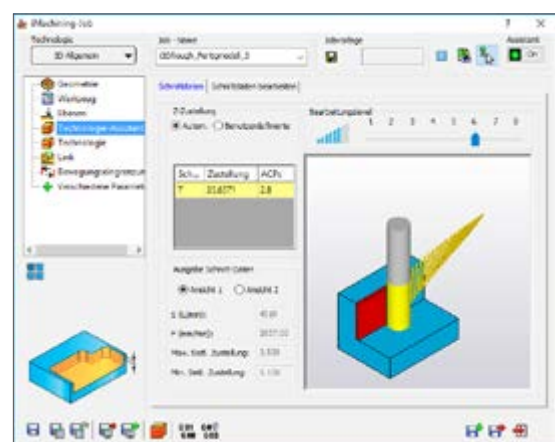

The “iMachining Level Slider” lets the user choose from 8 selectable levels to automatically adjust for “real-world” fixture, tool holding and machine conditions. The “iMachining Level slider“ makes it easy to overcome standard problems with spindle-rigidity, fixture-rigidity and excessive tool extension.

THE ORIGINAL
iMachining – exclusively from SolidCAM

TIME SAVINGS
70%
... AND MORE!



iRough, iFinish and iRest Technologies

- + Combined roughing, finishing and rest material functionality in one single job
- + iRough + iFinish: Roughing and contour finishing in just one job with the same tool. Ideal for prototype construction and processing of soft materials
- + iFinish: Suitable for precise machining and hard materials with separate tool for finishing wall and floor
- + Optimized rest roughing and bottom finishing of 2.5D geometries with various strategies
- + Automatic recognition and removal of rest material remaining through the drill tip

The patented iMachining Tool Paths!

Morphing Spirals – iMachining uses an advanced, patented morphing spiral that gradually conforms to the geometry of the feature being machined rather than an old-fashioned, simple spiral tool path (race-track). This maximizes tool to stock contact - or - "tool in the cut" time.

Moating: Divide & Conquer – In order to most efficiently attack large areas of material removal as well as stand-alone islands, they are separated or subdivided into smaller sections using iMachining's patented Moating technology. This maximizes the efficient morphed spiral cutting.

Eliminate Wasted Time & Motion – iMachining tool paths only cut the stock that needs to be removed, eliminating "air cuts". From the initial approach, right to the last cut, dynamically updated stock tracking ensures every tool path actually cuts material.

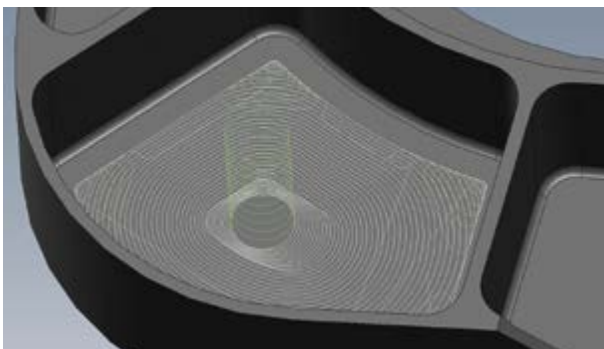

iMachining Morphing Spirals: Beyond Trochoidal Cutting

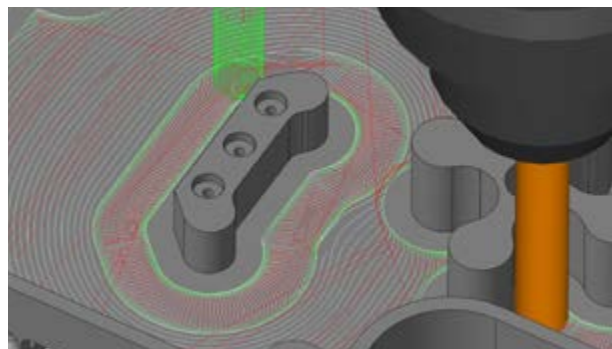

Moating: Intelligent dividing of areas

iMachining 3D for Prismatic Parts

Program and mill prismatic 2.5D parts with multiple pockets and islands quickly and efficiently!

While iMachining 2D requires user definition for each geometry (its chain and depth) resulting in several operations, iMachining 3D automatically identifies geometries and their depth, performing Roughing and Rest Roughing in a single operation. iMachining 3D for prismatic 2.5D parts calculates the toolpath automatically and optimally, drastically reducing programming and cycle time.

Reduced Cycle times

Metal Removal Rates (MRR) are maximized to achieve shortest possible cycle times whereas tool life is dramatically increased. iMachining 3D for prismatic 2.5D parts calculates the toolpath taking the complete solid model into account and not only single geometric chains. Depths of cut, the sequence of cutting areas and the positioning of the tool between 2D areas are automatically optimized – resulting in highest CNC and programming productivity.

Rest Machining

With decreasing tool diameters, any number of rest machining operations can be performed – taking into account the updated stock model: only the tight areas and corners will be machined.

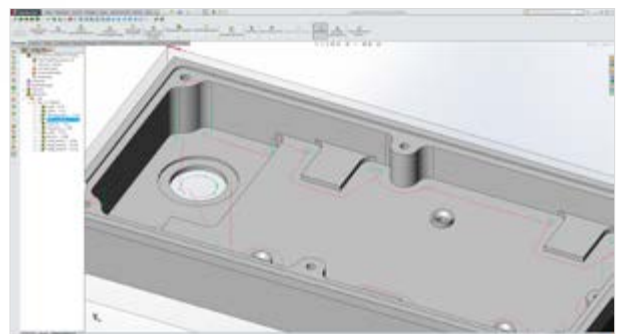
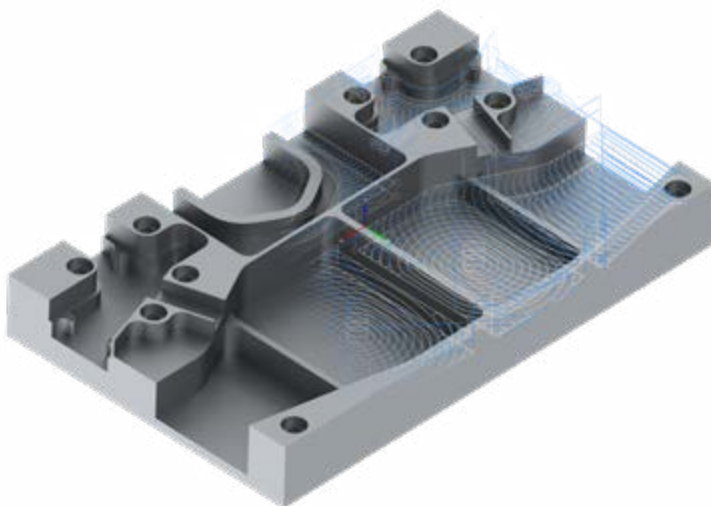

	iMachining 2D	iMachining 3D for 2.5D parts
Machining Time	16:05 min	13:53 min
Programming time	40 Minutes	5 Minutes
CAM-Jobs needed	24	3
Geometries needed	12	1 solid model

All data relate to the above part

THE ORIGINAL
iMachining – exclusively from SolidCAM

TIME SAVINGS
70%
... AND MORE!

Ultimate Process Reliability

In iMachining 2D the user defines the machined areas solely by using geometry chains. iMachining 3D for prismatic 2.5D parts uses the complete 3D model and automatically protects the target model from gouges. This is a major advantage when working with larger tool diameters and in confined spaces.

iMachining 3D for prismatic 2.5D parts adjusts the tool-path to avoid contact between the defined tool holder and the updated stock model, namely at every stage of the machining process. Tools can therefore be clamped shorter from the holder so machining can be faster and

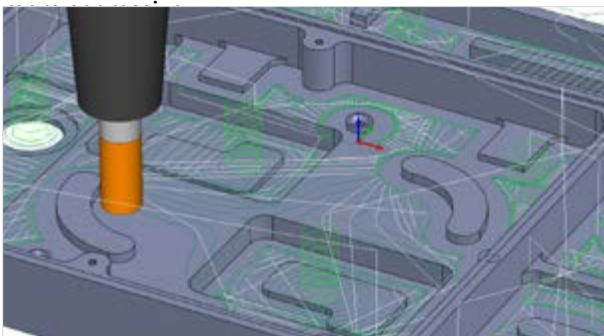

Automatic Finishing of Prismatic 2.5D Parts

Pocket recognition automatically identifies all pockets features along with their corresponding depths and at different levels, drastically reducing programming time. The complete finishing operation is performed in a single operation using a contour style pattern.



"Already after the first chip we were completely excited. Without iMachining we would have had hard nuts to crack with aerospace materials such as ultra-high strength steels with tensile strengths of more than 2,000 N/mm², aircraft aluminum, nickel based alloys and titanium."

Markus Gebhard, Dreiling Maschinenbau

"Thanks to iMachining, we have a much higher output from our machines, which definitely earns us money. Through iMachining we have won new customers, because now we can offer very good quality at a more competitive price!"

Drazen Perazic, Peramed Medical

iMachining 3D

Utilizing Proven iMachining 2D & Technology Wizard Algorithms for Roughing and Semi-Finish of Molds, Complex 3D Parts and 3D Prismatic Parts

Absolutely unique: iMachining 3D

- + Quick solid geometry selection
- + Optimized machining of each Z-Step, using proven iMachining 2D technology
- + Deep roughing with the whole length of the flute results in shorter cycle times and increases tool life
- + Rest material machining in small upward steps, optimized for constant scallop height, further shortens cycle time
- + Intelligent localized machining and optimal ordering eliminates almost all long positioning moves and retracts, producing the shortest times in the industry
- + A dynamically updated 3D stock model eliminates all air cuttings
- + Toolpath automatically adjusts to avoid contact between the holder and updated stock at every stage of the machining operation

iMachining 3D provides amazing 3D machining results, regularly saving 70% in machining time, in some cases reaching up to 90%.

iMachining 3D automatically produces a complete, ready to run CNC program, with optimal cutting conditions achieved by the expert knowledge-based Technology Wizard, to rough and rest rough a complete 3D part in a single operation for 3D surface models as well as prismatic parts.

A combination of its features full-depth step-down, intelligent step-up, localized machining and smart positioning eliminates nearly all retracts, long positioning and air cuttings. This enables iMachining 3D to achieve the shortest cycle times in the industry for roughing and semi-finish of molds, complex 3D parts and 3D prismatic parts.

Combined with SolidCAM HSM Finish, iMachining 3D provides a complete machining solution for 3D parts.

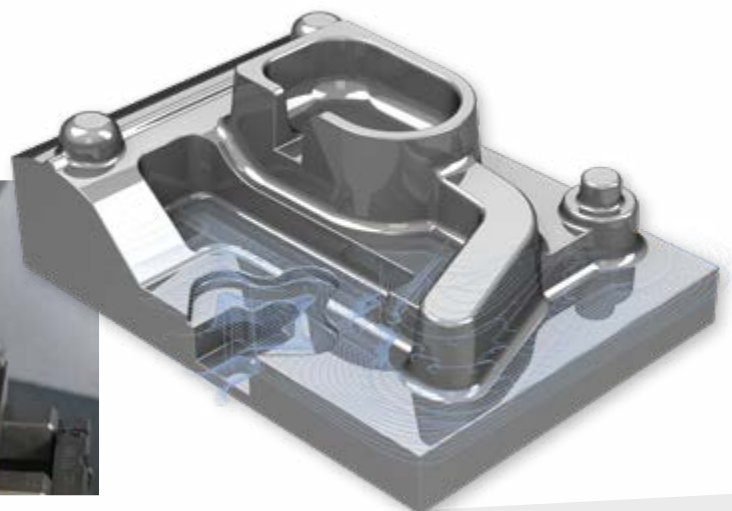



THE ORIGINAL
iMachining – exclusively from SolidCAM

TIME SAVINGS
70%
... AND MORE!



iMachining 3D for Prismatic Parts

iMachining 3D optimizes programming of prismatic parts with multiple pockets and islands. In a single operation you define the solid models of stock and part without the need of defining geometry chains. iMachining 3D then automatically calculates the optimal tool path – drastically reducing programming times.

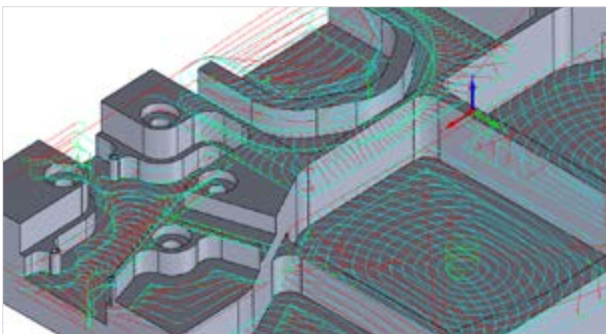

“We have freed up a lot of production capacity, have significantly increased our productivity, and reduced tool costs by more than half. The investment has more than paid for itself. For us, SolidCAM with iMachining is definitely a quantum leap.”

M. Torghele, Liebherr Werk Nenzing, Austria

“We use iMachining with nearly all our products – from 2.5D-, 3D- up to 5- Axis Machining. From today’s point of view, it is a no-go to work without it.”

A. Winkler, Zrinski AG, Germany

2.5D Milling

The Most Powerful & Easiest Way to create 2.5D CNC Milling Toolpaths: Full Interactive Control + Feature Recognition!



The most straightforward, easy-to-use interface, seamlessly integrated in SOLIDWORKS, combined with the latest toolpath technology, provides the fastest, most powerful and easiest to create 2.5D CNC Milling toolpaths.

Easily work on parts, assemblies, and sketch geometry to define your CNC machining operations. Quickly place fixtures and components for full visualization.

Best of Both Worlds: Complete Interactive Control + Feature Recognition

SolidCAM provides both interactive and automated 2.5D milling operations on SOLIDWORKS models. Designed for both the novice and advanced user, SolidCAM offers the best of both worlds, with your choice of fully controlled selection of geometry, parameters and CNC programming strategies or Automated Pocket and Drill Recognition and machining.

Interactive 2.5D Mill Operations

Besides the standard 2.5D milling profiling, pocketing and drilling operations, SolidCAM offers:

- + Chain modification options (offsetting, trimming, extending etc.), enabling changes to geometry without changing the CAD model
- + Automatic rest material machining to cut the material remaining after using larger tools
- + Chamfer machining using the same geometry defined in Profile and Pocket operations
- + Thread Milling operation for machining of standard internal and external threads
- + Variable levels of pockets and profiles in one single job
- + Engraving of text on flat and wrapped faces and middle line engraving of a multi-line text
- + Contour 3D operation drives the tool along a 3D curve, cutting the model at different depths
- + Machining of geometry wrapped around rotation axes, by transforming linear movement to rotary movement

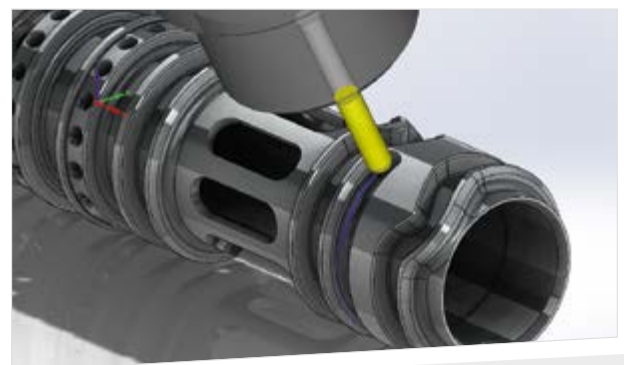

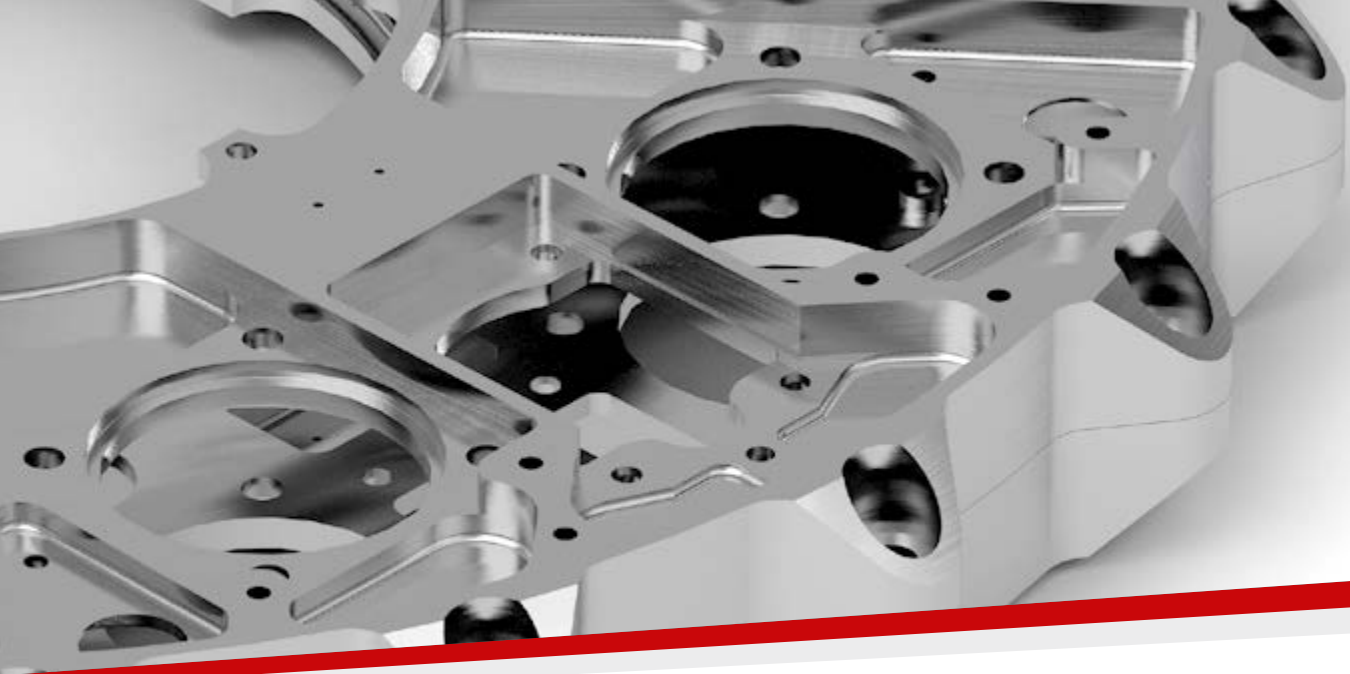

➕ Special operation for machining of the side slots with undercut by a T-slot tool.

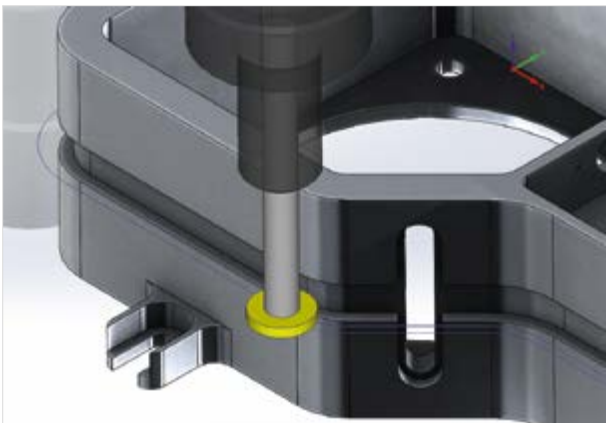

Pocket Recognition

Takes SolidCAM's powerful pocketing operation to the next level, by automatically identifying all pockets on the CAD model. All strategies and options of the standard Pocket operation are available, combined with variable levels and depths recognized from the model faces.

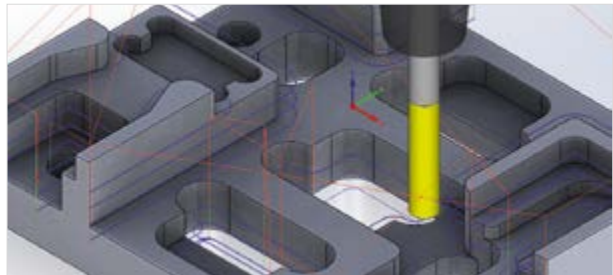

Drill Recognition

Automatic recognition and grouping of holes from the solid model with option to modify resulting geometry. A single Drill Recognition operation can machine groups of holes on varying levels and depths.

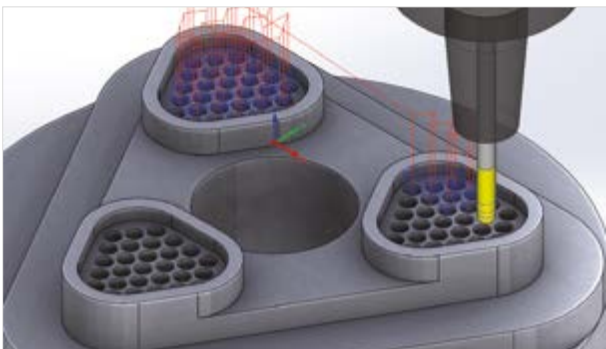

Cycle Toolbox

A very useful and convenient Cycle Toolbox provides additional specialized sub-operations for slots, corners, bosses, ruled surface, etc.

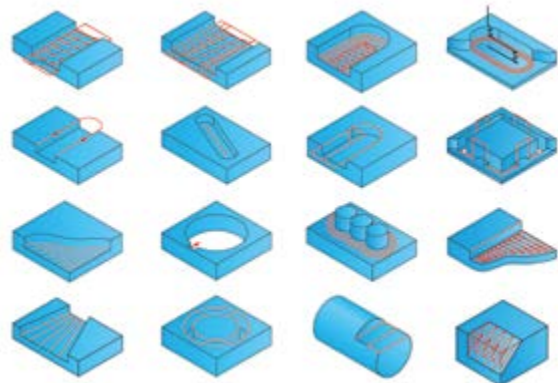

Automatic Feature Recognition & Machining

Pockets, Chamfers and Drills – SolidCAM AFRM almost automatically generates ready-to-run CNC-Programs for all 2.5D Operations!

Advanced Pocket Recognition

SolidCAM AFRM sets the new standards. Instead of machining each individual pocket in a separate operation, all pockets, no matter whether they are open, closed, blind or through Pockets, are being identified with their corresponding depth and Z-level and machined in one operation.

- + All strategies and options of the standard pocket operation are available, combined with variable upper levels and depths recognized from the model faces. User controls the choice of the Tool, Technology and Cutting Strategy.
- + Automatic recognition and machining of fillets on the Pocket floor.
- + Automatic rest material recognition on each pocket.
- + The perfect tool for multi pocketed parts.

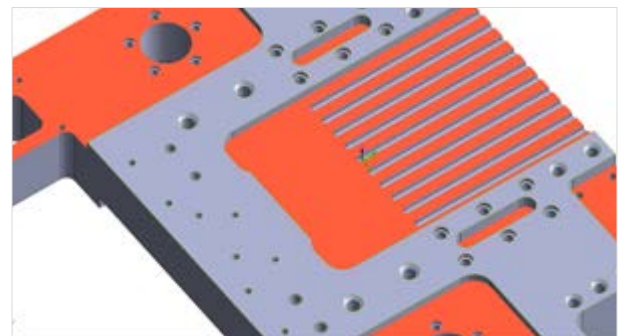

Chamfering and Deburring

SolidCAM automatically recognizes all sharp edges where a chamfer can be applied. The user only sets the depth of the chamfer, the cutting diameter of the tool and a safety offset. SolidCAM's chamfer recognition automatically avoids vertical walls and machines as much as possible, while protecting the part from collisions with the shank.

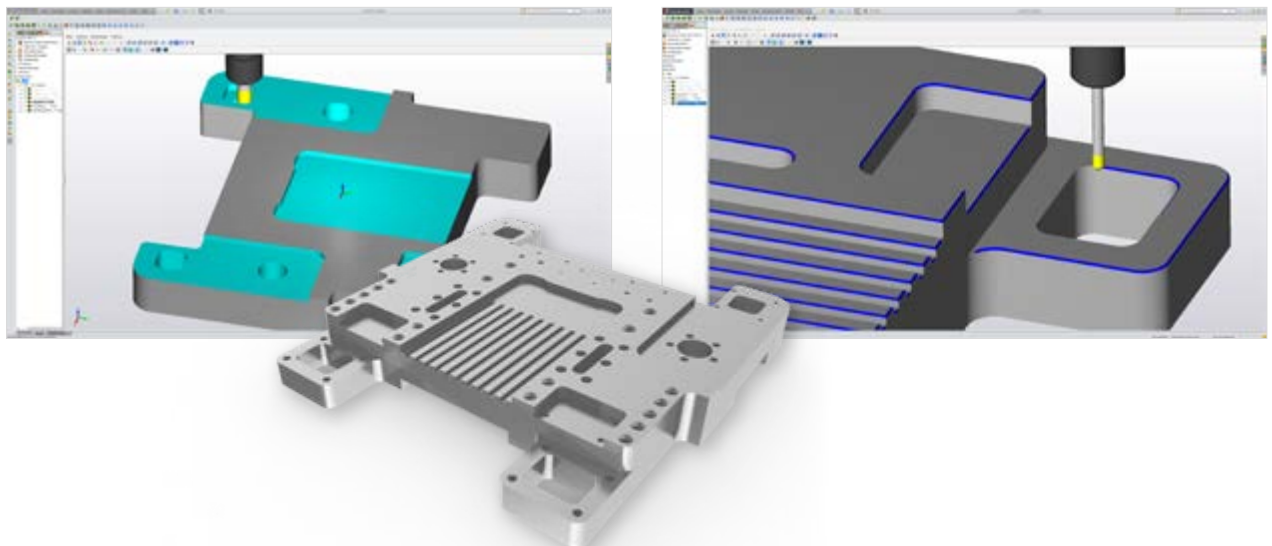

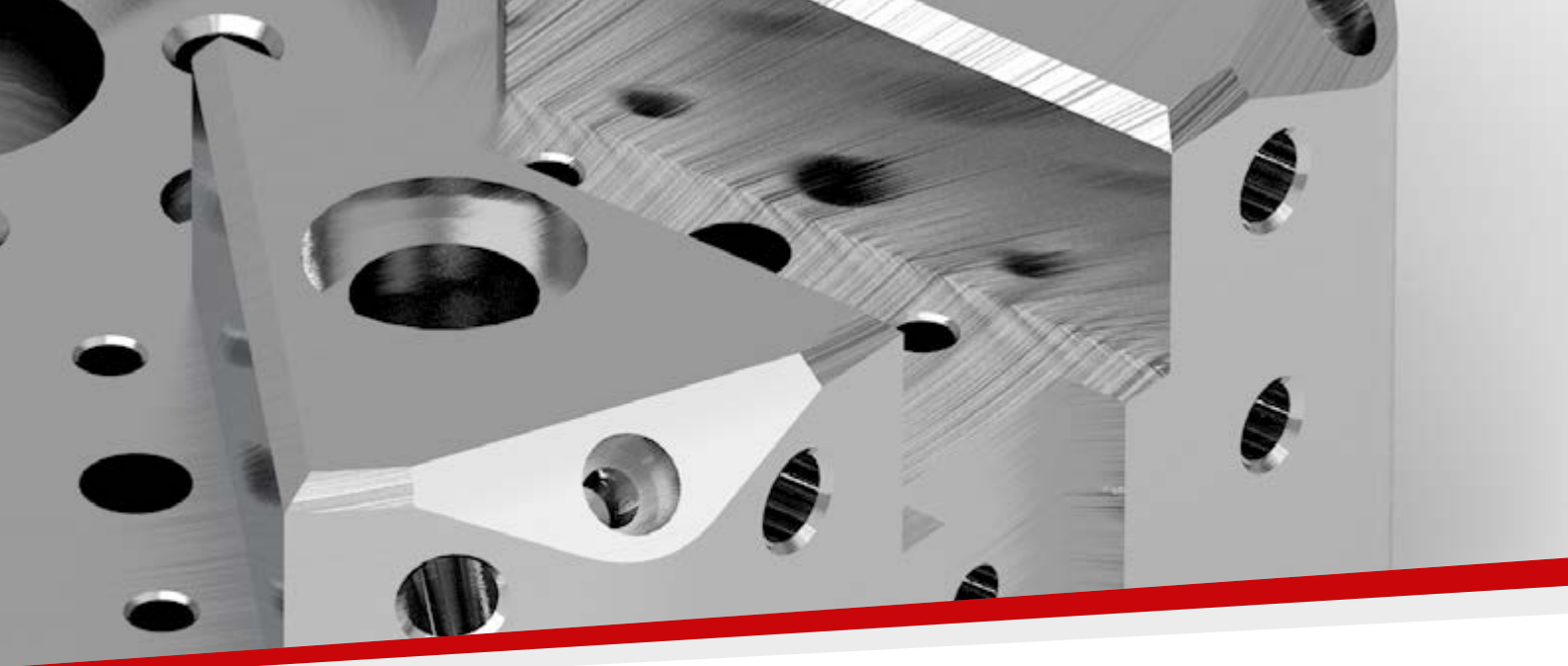

Advanced Drill Recognition

SolidCAM automatically identifies all drills on the solid model and generates the necessary CNC operations.

- To select the drills to be machined, powerful filter tools such as diameter, Z-level or drill depth are available
- Spot drills can be generated on all drill positions where the depth relates to the diameter of the drill tool being used

SOLIDWORKS Hole Wizard

In SOLIDWORKS all major hole features and types can be quickly configured using the Hole Wizard. SolidCAM uses the data from hole features perfectly.

- All parameters of the SOLIDWORKS hole features Counterbore, Countersink, Hole, Straight Tap, Tapered Tap and Legacy Hole are inserted and mapped into SolidCAM Machining Processes.

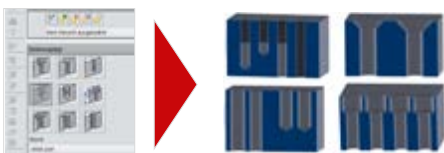

- From the geometry entities that are input from the SOLIDWORKS Hole Wizard, SolidCAM automatically creates and uses geometries for profile & pocket milling operations.

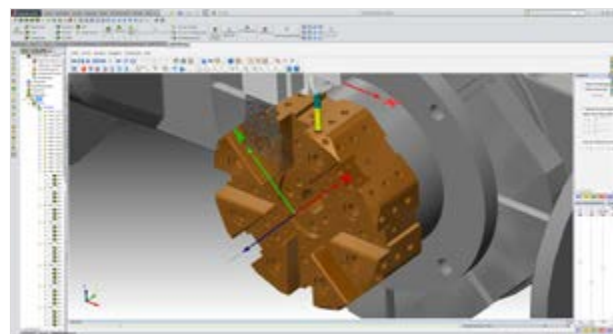
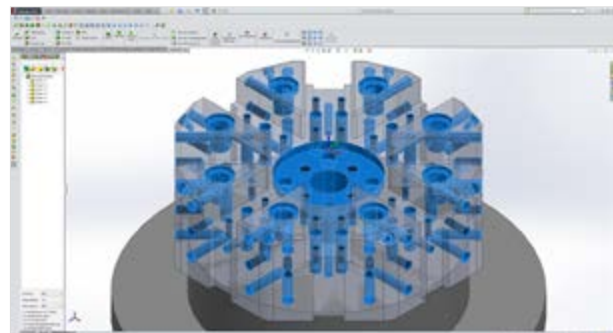
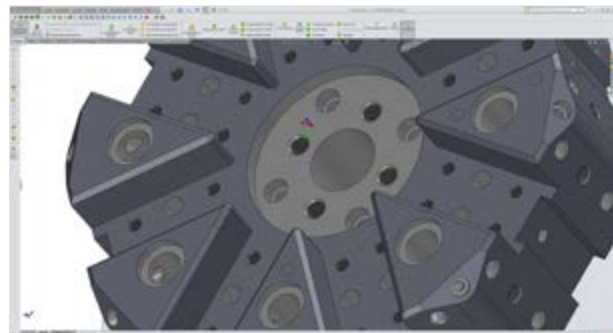
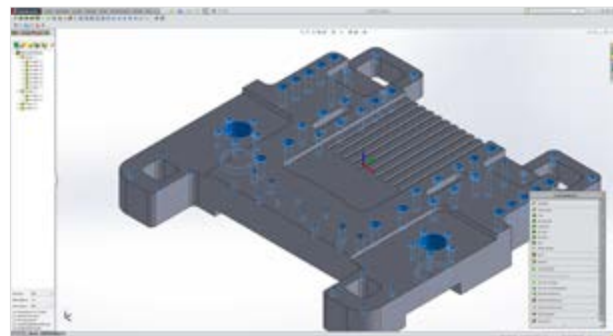

HSS

High Speed Surface Machining of Localized Surfaces – Important Module for Every Machine Shop!

SolidCAM HSS is a high speed surface machining module for smooth and powerful machining of localized surface areas in the part, including undercuts. It provides easy selection of the surfaces to be machined, with no need to define the boundaries. It supports both standard and shaped tools.

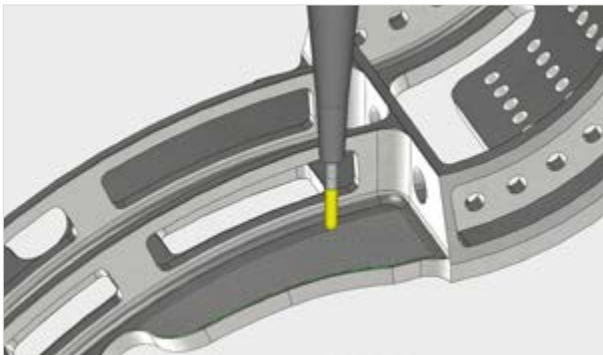

Powerful Surface Machining Strategies for Smooth, Gouge-Free & Optimal Toolpaths

The SolidCAM HSS Module provides numerous surface machining strategies, that produce an efficient, smooth, gouge-free and optimal toolpath to finish the selected surfaces.

HSS provides special toolpath linking options, generating smooth and tangential lead-ins and lead-outs. The linking moves between the toolpaths can be controlled by the user to avoid holes and slots, without the need to modify the model's surface. Retracts can be performed to any major plane.

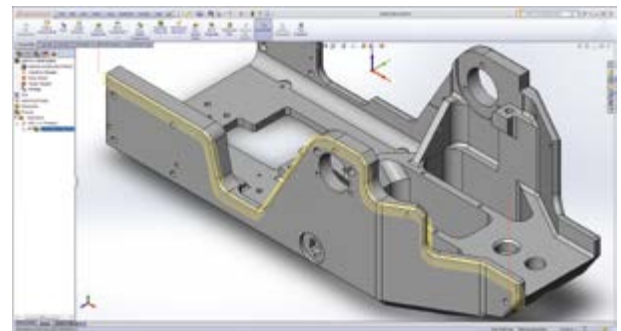

Total Tool Control to Machine Only the Areas You Choose

HSS is the CAM module that takes your 2.5D machining way beyond profiles, pockets and faces, providing a 3D machining capability by driving along specific surfaces on prismatic and 3D parts.

The HSS toolpath is focused on single or multiple surfaces and excels in creating a flowing toolpath on a group of surfaces that make up a complex 3D shape, e.g. fillets.

Experience total tool control to machine only areas you choose, without the need of constraint boundaries or construction geometry.

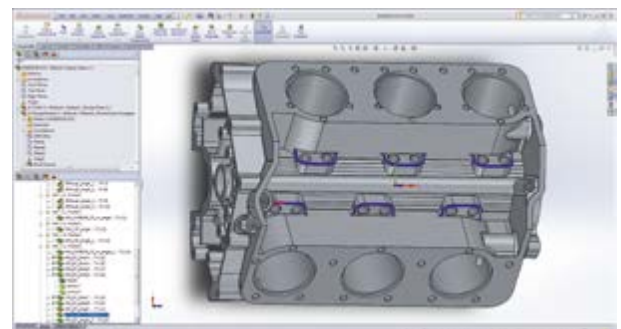



Advanced Gouge Control for Holder, Arbor and Tool

Complete Gouge Control is available for Holder, Arbor and Tool. Adjoining Check Surfaces that are to be avoided can be selected. Several retract strategies are available, under full user control.

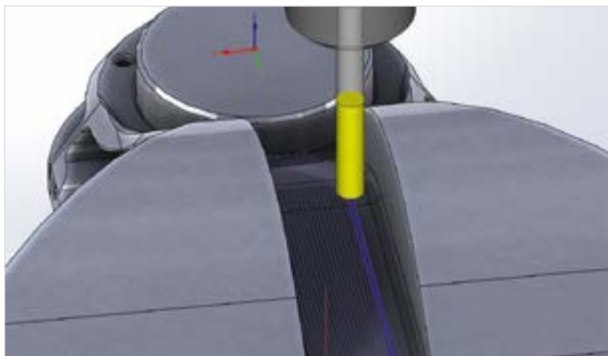
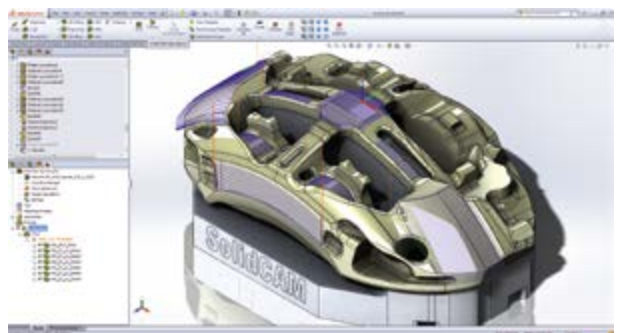

Important Module for Every Machine Shop

The advantages of the SolidCAM HSS module translate to significantly increased surface quality. The HSS module is an important and valuable add-on for every machine shop for the machining of all types of parts.

Advanced Linking

Total freedom to control tool entry and tool exit motion, to remove the need for surface modifications. Tool-paths can be extended or trimmed, gaps and holes can be jumped and you can choose from multiple lead-in/lead-out options.

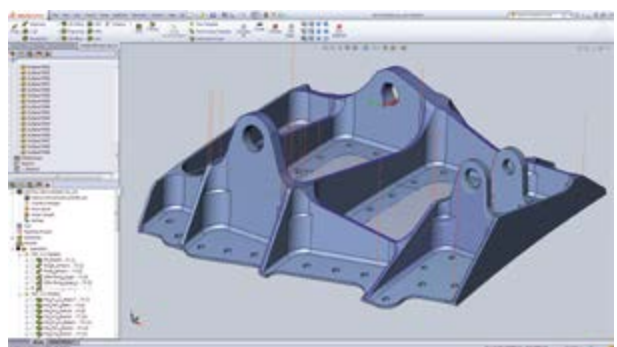

Handling Undercut in HSS

Use Tapered, Lollipop, or T-Slot tools for undercuts or difficult to cut geometry.

Indexial 5-Axis Milling

Powerful SolidCAM Indexial, Multi-Sided Machining – Easiest Coordinate System Definition!

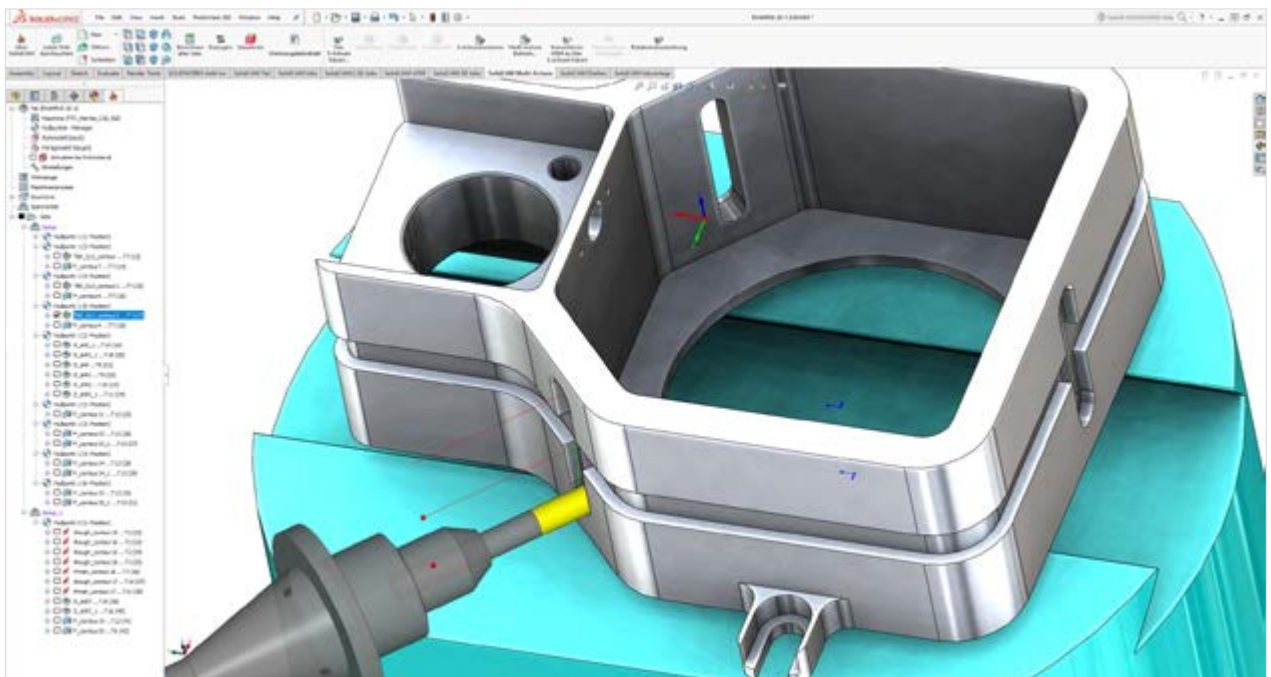

A common scene in any machine shop today is that 4- and 5-axis CNC machines are increasing production, providing faster cycle times.

SolidCAM provides an effective and easy way to program on multiple sides of a part. SolidCAM is exceptionally strong in indexial 4/5-axis machining.

Easiest Coordinate System Definition for Indexial 5-Axes!

Tired of dealing with construction views, copying models, and rotating them in space for new alignments? Do you still copy and transform geometry to separate layers for indexial programming?

Experience single machine home position, with One-click orientations for indexed setups – SolidCAM speeds up multi-sided machining by eliminating multiple coordinate system constructions. Define a Coordinate System on the fly, by just picking a face, and continue programming your part.

- + SolidCAM's "select a face and machine" is the fastest approach to indexial programming
- + Our coordinate system manager keeps track of all necessary data for each tool orientation
- + SolidVerify simulation shows tool holders and fixtures, together with material removal for all machining operations

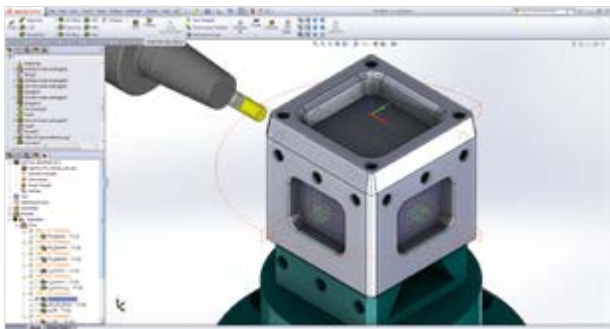

Efficient, Edit-Free G-Code for Multi-Axis Machines

SolidCAM offers multiple options to get efficient G-code for multi-axis machines.

SolidCAM's post processor can be set up to handle all rotations and work offset shifting, to eliminate the need for setting up multiple work offsets at the machine. Whether your controller can calculate part rotations internally or it needs the post processor to handle rotations, SolidCAM has this covered. For controllers with

advanced plane rotation or coordinate rotation functions, SolidCAM's post processors are built to use these internal CNC functions. If you have a machine without such functions, users can input the part location inside SolidCAM and the G-code will handle all of the transformations for each rotation.

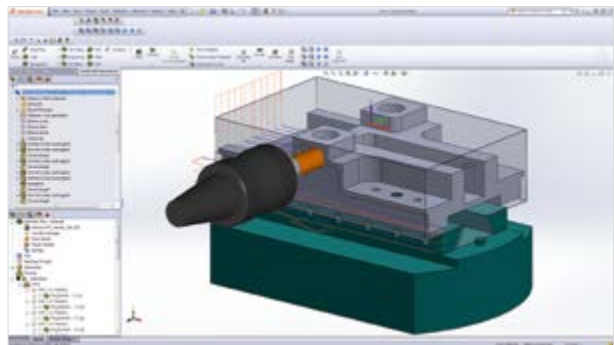

Our philosophy to indexial milling is simple: from software to G-code – make the process for indexial milling the same as for single-sided milling. No need for any special functions or tricks inside the software to machine multi-sided parts – it should just work!

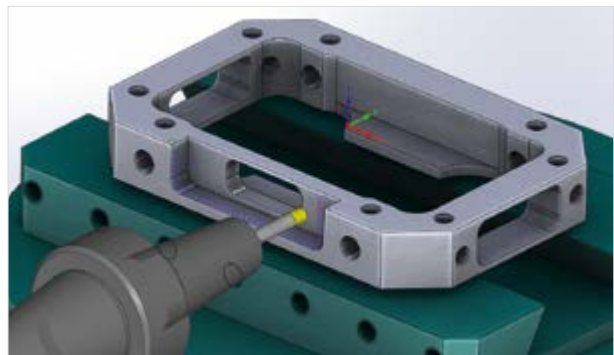
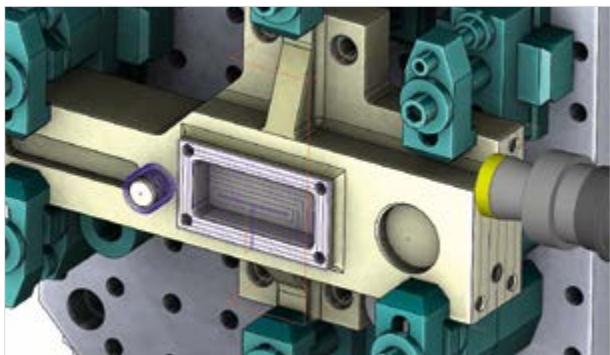

HSR & HSM – 3D High Speed Machining

*Efficient Roughing and the Finest Finish
Toolpaths available for 3D Machining!*

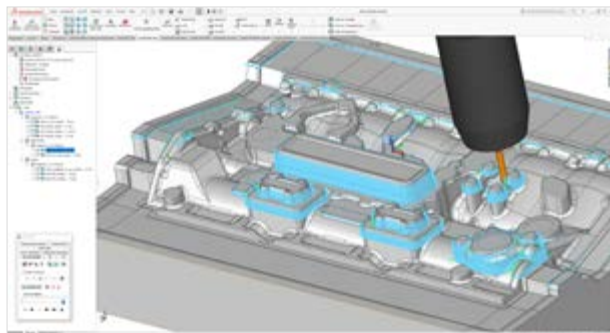

Experience 3D machining taken to an entirely new level of smoothness, efficiency and smart machining, with the finest toolpaths available anywhere for complex 3D parts, aerospace parts, molds, tools and dies.

SolidCAM High-Speed Machining offers unique machining and linking strategies for generating 3D high-speed toolpaths. It smooths the paths of both cutting moves and retracts, wherever possible, to maintain a continuous machine tool motion – an essential requirement for maintaining higher feed rates and eliminating dwelling.



HSR – High Speed Roughing

SolidCAM HSR provides powerful high-speed roughing strategies including contour, hatch, hybrid rib-roughing and rest roughing.

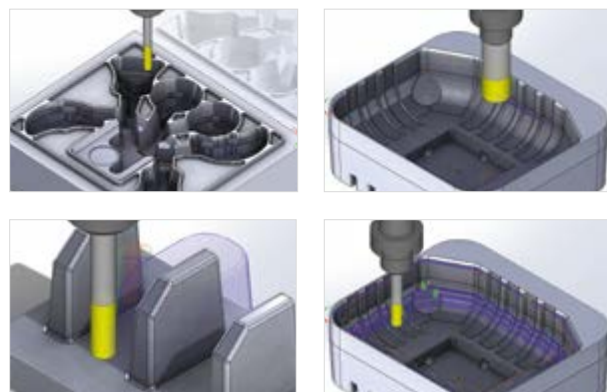

HSM – High Speed Finishing

With SolidCAM's HSM module, retracts to high Z levels are kept to a minimum. Angled where possible and smoothed by arcs, retracts do not go any higher than necessary, minimizing air cutting and reducing machining time.

The result of HSM is an efficient and smooth toolpath that translates to increased surface quality, less wear on your tools and a longer life for your machine tools.

With demands for ever-shorter lead and production times, lower costs and improved quality, High Speed Machining is a must in today's machine shops.

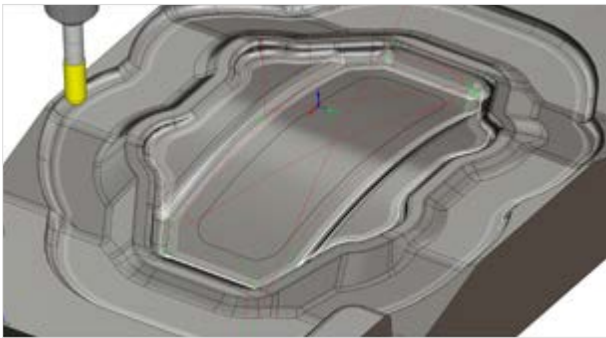

HSM – 3D Machining to the Highest Level

SolidCAM HSM module is a powerful solution for all users who demand advanced High-Speed Machining capabilities. It can also be used to improve the productivity of older CNC's with reduced air cutting and smoothing arcs that maintain continuous tool motion.

Let us show you how HSM takes 3D Machining performance to the highest level – all with your current machines.

The SolidCAM HSM module features several enhancements to CAM technology that make high speed operations possible, e.g. avoiding sharp angles in the tool path and generating smooth and tangential lead in/out. The tool stays in contact with the material as much as possible and non-machining moves are being reduced.

The working area of any HSM 3D job can be precisely controlled. To achieve this, a extensive set options is available, including silhouette boundaries, cutter contact area boundaries, shallow area boundaries, rest area boundaries, user defined boundaries or by entering limits for surface slope angles.

In addition, HSR/HSM toolpath can be edited after toolpath creation. Working areas, Z-level limits or a combination of both can be used to control cutting moves or to exclude specific areas from machining.

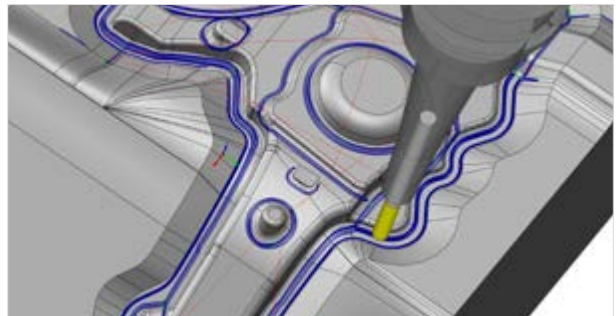

Simultaneous 5-Axis Milling

Advanced Simultaneous 5-Axis Toolpaths with a Very Friendly User-Interface

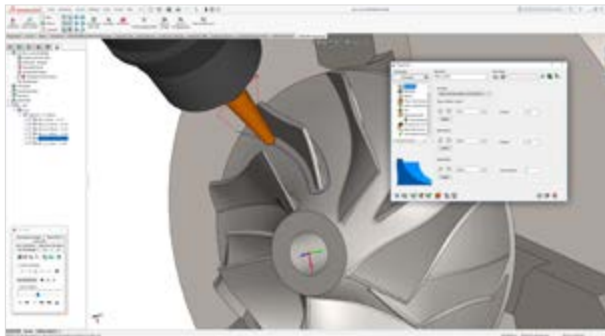

Benefit from the most tested and most proven 5-Axis machining tool paths in the industry with a user-friendly interface, collision checking and the most advanced control over all aspects of tool path:

- + Wide variety of Simultaneous 5x cutting strategies
- + Flow line cutting produces a toolpath that follows the natural shape of the component
- + Multi-surface finish machining keeps the tool normal to the surface (or with specified lead and lag) to provide a smooth surface finish
- + Advanced tool tilting control and direct control on side tilting and lead/lag angles
- + Automatic collision avoidance strategies that check each part of both the tool and holder
- + Multi-axis rest roughing efficiently removes the remaining material of the larger cutter diameter used previously
- + Realistic full 3D machine simulation with comprehensive collision and axis limits checking

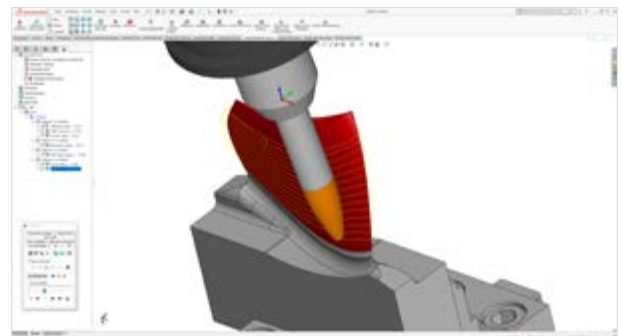

Circular-segment cutters with barrel-, oval- and tapered geometry are being supported in SolidCAM

Flexibility and Control

Each 5-Axis machining strategy provides sophisticated options for approach/link control and tool axis control.

Link and approach moves are fully gouge protected and different strategies may be used depending on the distance of the link move. SolidCAM also provides options for control over lead/lag and side tilt angles to give complete control over the final toolpath.

Collision Avoidance for Tool and Holder

Collision avoidance is supported for both the tool and holder, and a range of strategies is offered for avoiding collisions. The Machine Simulation provides complete visualization of the gouge checking.

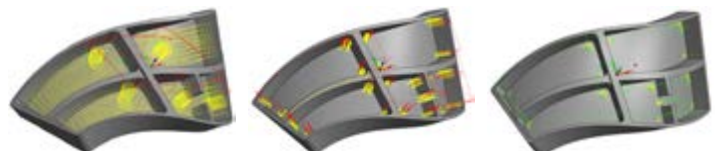



SWARF Machining

With SWARF machining, the tool is being tilted over to cut with its lateral surface. SWARF cutting utilizes the complete cutting length of the tool, resulting in better surface quality and shorter machining time.

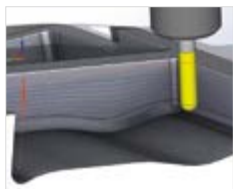

Multi-Blade Machining

The Multi-blade machining operation easily handles impellers and bladed disks, with multiple strategies to efficiently rough and finish each part of these complex shapes, which are being used in many industries.

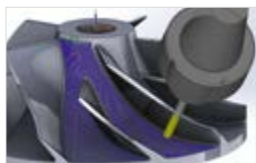

Port Machining

With this 5X-job you can machine intake and exhaust ducts as well as inlets or outlets of pumps etc. in castings or steel blocks with tapered lollipop tools. Roughing and finishing operations can be quickly and easily defined and reliably simulated with complete collision control of the entire tool and holder.

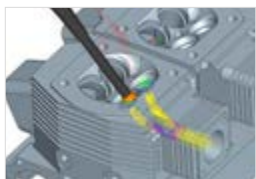

Screw Machining

This job generates 4-Axis rotary roughing and finishing tool path for screws using bull nose, ball nose or flat end mills.

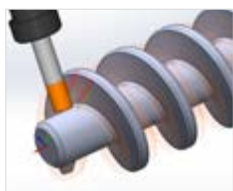

Contour 5-Axis Machining

The Contour 5-axis machining strategy tilts the tool along a chained 3D profile drive curve, while aligning the tool axis according to defined tilt lines, making it ideal for generating 5-axis toolpath for deburring and trimming.



Multi-Axis Drilling

The Multi-Axis Drilling operation uses SolidCAM's automatic hole recognition and then performs drilling, tapping or boring cycles, at any hole direction easily and quickly. All the advanced linking, tilting and collision avoidance strategies are available in this operation.



Convert HSM to Sim 5-Axis

The Convert HSM to Sim 5-Axis milling operation converts HSM 3D toolpaths to full 5-Axis collision-protected toolpaths. This will maintain optimum contact point between the tool and the part and enables the use of shorter tools for more stability and rigidity.

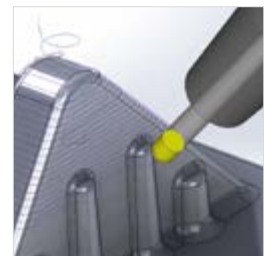

Turning

SolidCAM Module for Fast and Efficient Turning

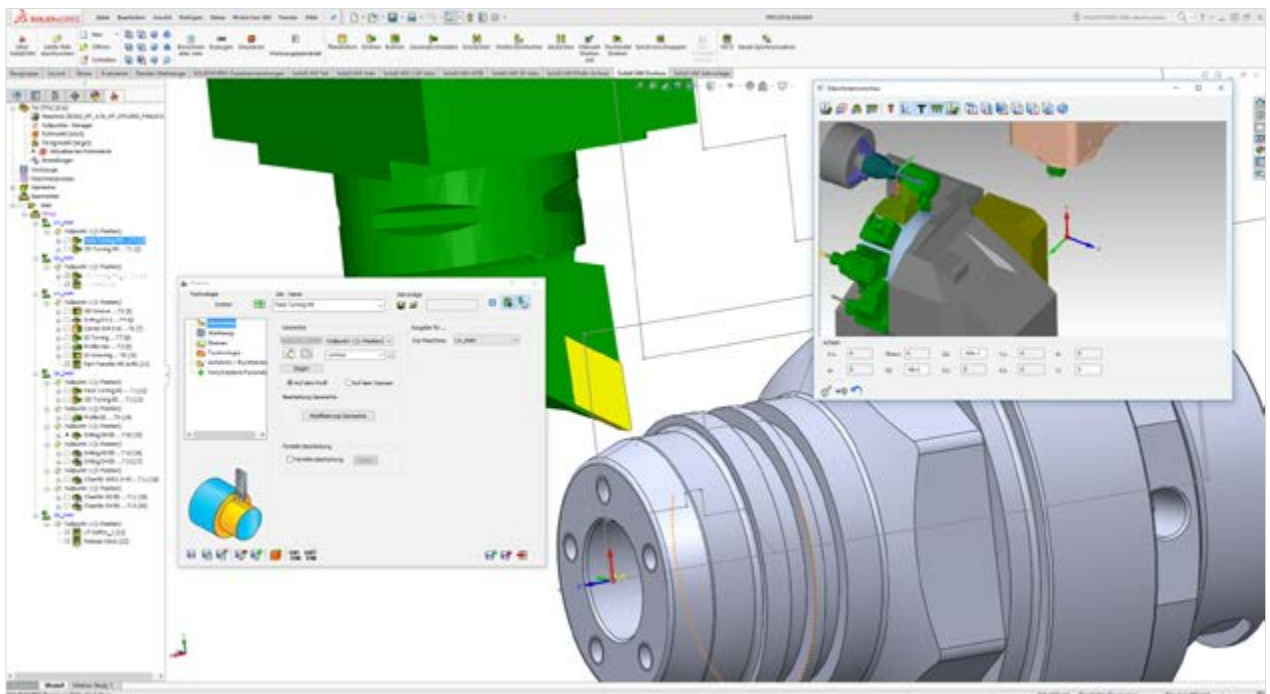

- + SolidCAM provides a comprehensive turning package with powerful toolpaths and techniques for fast and efficient turning.
- + SolidCAM produces advanced rough and finish profile turning, together with support for facing, grooving, threading and drilling.
- + SolidCAM turning supports the widest range of machine tools, including 2-Axis lathes, multi-channel configurations, sub-spindle turning centers and even the most complicated Mill-Turn machines.
- + Turning geometries and profile can be generated very quickly, easily adopted or modified for production.

The new interactive Machine preview in SolidCAM shows a STL-model of the machine with full axis kinematics as well as the home positions of all components. Tools, fixtures and machine control operations (MCOs) are displayed in real time – facilitating CAM programming and collision control without any extra software tools.

A new tool wizard helps you to set-up or add new tools on the turret quickly and easily. In addition to the realistic display of all tools on the turret, the SolidCAM turning module employs advanced collision checking for all tools with any machine elements.



Advanced Turning Operations

- ⊕ **Balanced Roughing:** two tools working simultaneously or in trailing mode, to perform roughing turning of long and large parts.
- ⊕ **Angled Grooving:** performs internal or external inclined grooves, at any defined angle.
- ⊕ **Manual Turning:** performs turning according to user-defined geometry, regardless of stock and target model.
- ⊕ **Trochoidal toolpath of round grooving tools** for increased efficiency
- ⊕ **4th Axis Simultaneous Turning:** performs machining of curved profile using the B-axis tilting capabilities of the tool, in order to machine undercut areas in a single machining step.
- ⊕ **Multi-turret Synchronization:** provides powerful tools to synchronize your Multiple Turret machines. A machining time line, with all operations and simple commands, enables you to align operations that will be synchronized. Afterwards, you can see the result of synchronization in SolidCAM's advanced Machine Simulation.

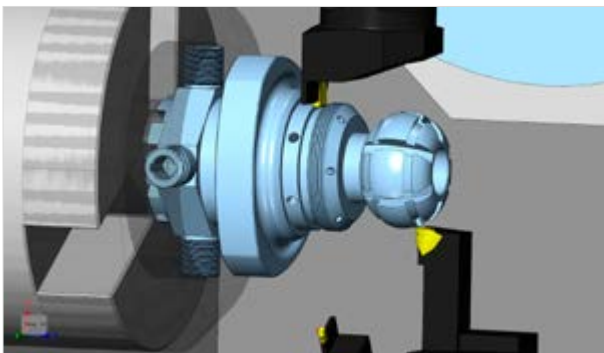

MCO (Machine Control Operation)

MCO (Machine Control Operation) enables the user to insert various control operations while manufacturing a part. These operations control the CNC-Machine and activate different options and devices such as the opening or closing of fixtures, activating coolants, rotating the part or moving the part from one table to another.

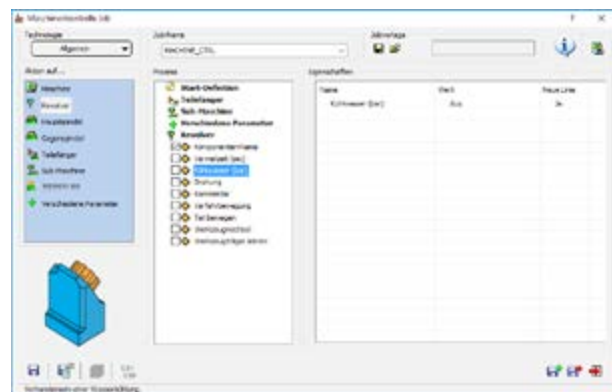

Updated Stock

SolidCAM has the ability to keep the stock updated live within the operations tree. Updated stock is supported from the most basic 2-Axis Turning Center, right through to a CYB Multi-turret, Sub-spindle Mill-Turn CNC-Machine.

On a Sub-spindle Turning Center, when a component is transferred from the main to the sub-spindle, the Updated stock model is transferred with it. Any subsequent machining on the sub-spindle will detect the stock in the state that it left the main spindle, ultimately providing the most efficient machining sequence possible.

Advanced Mill-Turn

Easy Programming for Complex Multiple Turret and Multiple Spindle CNC Machines and Swiss-type Machines

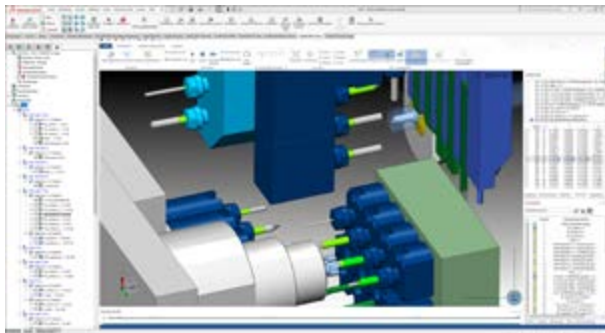

Citizen L20 in SolidCAM's complete machine simulation

The fastest growing and most demanding class of CNC-Machines are multi-task machines that combine several capabilities into one machine. SolidCAM's Advanced MillTurn module provides you with all features and functions to reliably and quickly program even the most complex multi-functional CNC-Machines. SolidCAM is easy to learn and to use, yet offering you ultimate flexibility and configurability.

- + Within a single user interface all Turning and Milling operations on main and sub-spindles, rotary and linear turrets, tail stocks, steady rest etc. can be programmed.
- + Ancillary devices can also be defined and considered during simulation and gouge checking.
- + All Turning and Milling operations, including the unique, revolutionary iMachining technology can be used and simulated in SolidCAM's advanced machine simulation.

- + Intelligent management of rest material between all operations, both Milling and Turning, results in the most efficient tool paths and reduced cycle times to bring you maximum productivity.
- + Additions to Tool library made easy: the interactive Tool-mounting assistant for the creation of new tools shows all other tools on the turret, the preview of the machine, the position of the axes and their precise direction of rotation.

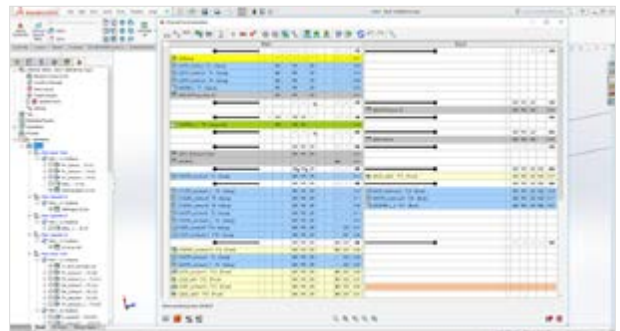

Optimized Channel Synchronisation

Machining jobs of the NC channels can be re-sorted without any issues. This allows synchronization between the beginning and the end of the entire process. The machining of several workpieces on different spindles can be displayed simultaneously. All machine axis and gears are constantly monitored and any issues are highlighted in quick infos.

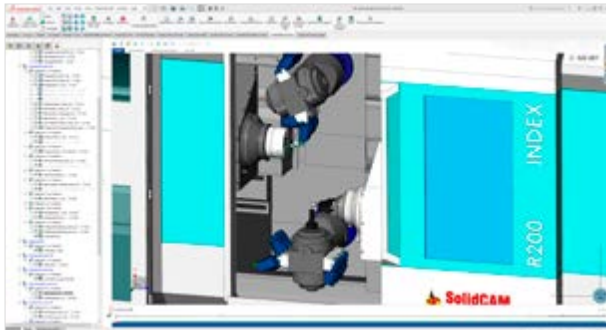
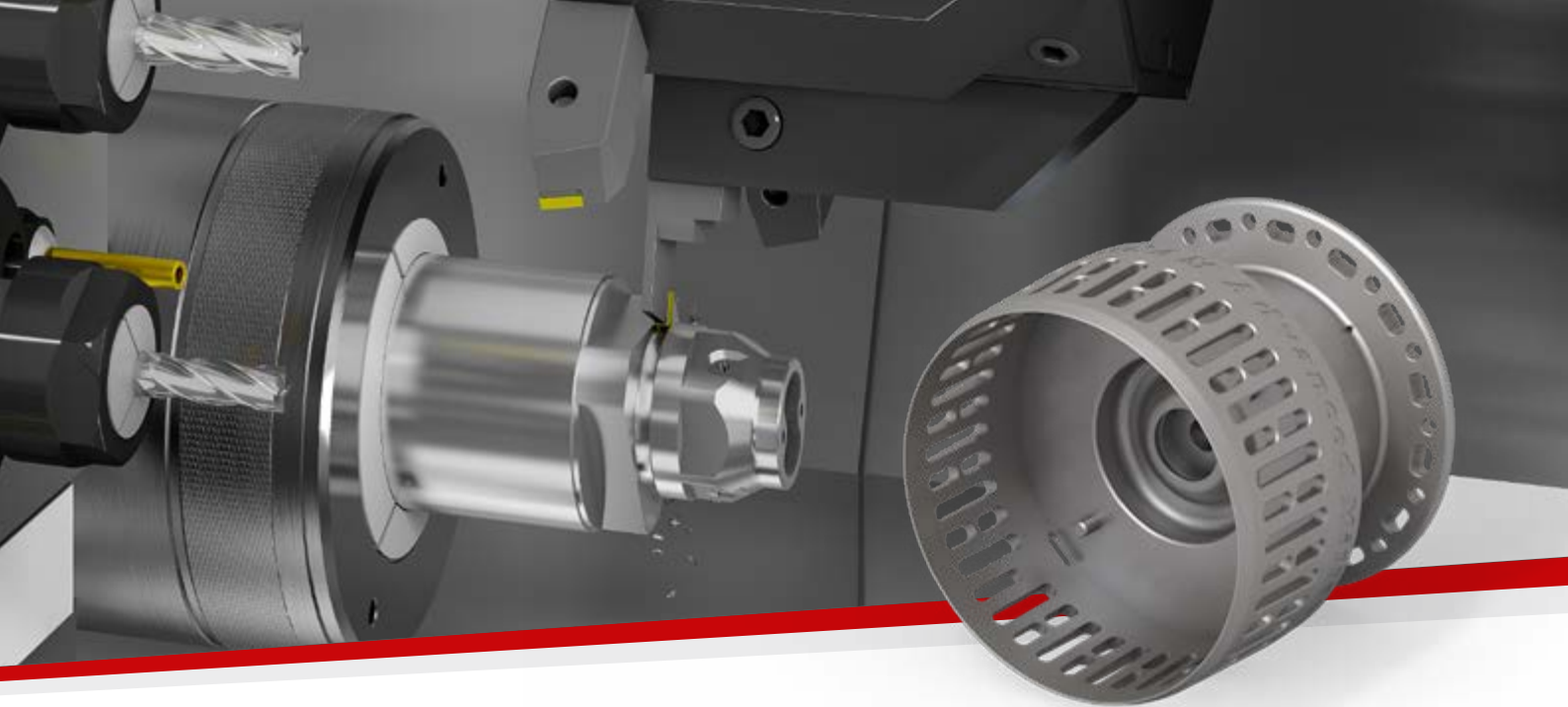

INDEX R200 machine simulation

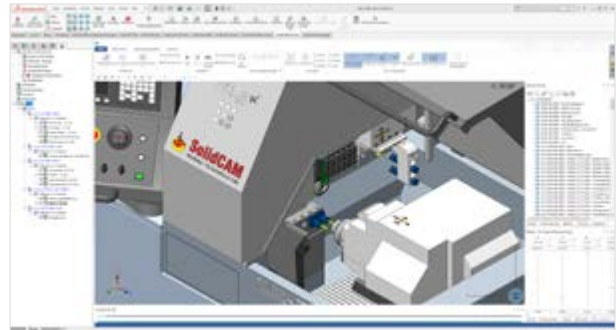

STAR SB 20R Typ G machine simulation

Support for complex Machines

The VMID (Virtual Machine ID) defines the all CNC-Machine components and machine kinematics. In SolidCAM even the most complex MillTurn centers, Swiss-type Machines and CNC sliding headstock automatic lathes can be set up and programmed effectively.

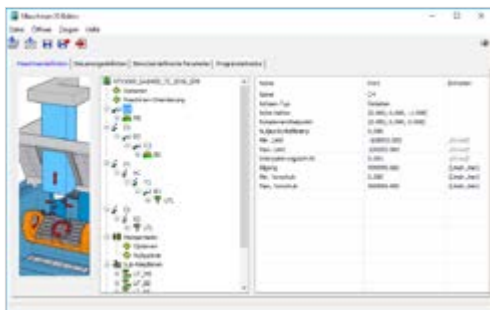

Transfer between Spindles

Control the transfer of parts between the main and sub-spindle, using Machine Control Operations. Ready made MCOs provide the best solution for this process.

Mill-Turn Machine Simulation

SolidCAM Mill-Turn offers a full kinematic simulation package, supporting all turning and milling operations and CNC machine components and devices. The simulator provides full collision detection between machine components, workpiece, fixtures and tool holders.

All the cycles and movements are supported along with the full graphics of the machine components and auxiliary devices such as tail stock and steady rest, providing safety as the part is fully tested before reaching the actual machine tool.

Post processors

Employing its own, highly customizable post processor language, SolidCAM supports even controller specific programming structures and functions. With no manual editing needed, generated G-code can be sent straight to the the CNC-machine

```

M00F
*****
M010-062_314          ; KULLPOINT SPINDEL 4
M011-056             ; FUHRKOLLENE SPINDEL 4 MIT VORRUECKTE NACKEL/DAMPF
M012-019_01         ; FUHRKOLLENE SPINDEL 3 MIT VORRUECKTE NACKEL/DAMPF
M013-019_01         ; SEHRTEILE SPINDEL 3 MIT AUSSTRECKER
M014-0             ; SEHRTEILE SPINDEL 3 MIT AUSSTRECKER
M015-036_01         ; WERKSTUCCERLAGER FUHRWITTEL
M016-060            ; ANNEHTRAGKOLLENE G1-ACHSE
M017-0             ; WIRKUNGSBATE SPINDEL 4
M018-0             ; WIRKUNGSBATE SPINDEL 3
M019-0             ; VERKAT SPINDEL 3 BU SPINDEL 4
M020-0
M021-0             ; FARMER AUF FESTBANKELAS 0-HEIN / 1-26
M022-0             ; UMKLAEPFERN BELI FARMER AUF FESTBANKELAS
M023-0             ; FERTIGER LINEE BELI FARMER AUF FESTBANKELAS
M024-0             ; FERTIGER BACHTS BELI FARMER AUF FESTBANKELAS
M025-0_01          ; ANNEHTER NACH FARMER AUF FESTBANKELAS
M026-0
M027-0             ; SCHTELLUNGSWISSE
M028-0             ; SPITZABSCHREIBUNG 82-NORME 0891
*****
M029-M010-M019      ; KURAMA KULLPOINT SPINDEL 4
M030-M012-M015-M018 ; KULLPOINT USA
M031-M013-M016-M017 ; KULLPOINT USA
M032-M018-M019-M025 ; KULLPOINT SPINDEL 3
M033-M024-M025     ; KULLPOINT SPINDEL 3
M034-M021-M022     ; KULLPOINT SUB ANNEHTER MIT G1-ACHSE
  
```

Solid Probe

Integrated CAM Module for Probing, Home Definition, Measuring and On-Machine Verification



Probing & Measuring Made Easy

SolidCAM is bringing you Solid Probe, a new SolidCAM module that provides capabilities for Home definition and On-Machine Verification, using probes on the CNC machine, to do setup and control the quality of machined parts.

Full visualization of all the probe movements, provided by SolidCAM Machine Simulation, enables you to avoid any potential damage to the Probe tool.

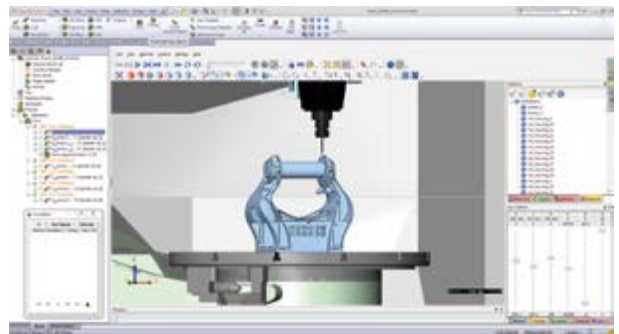

Solid Probe is a Must Module for Every Machinist using Probes:

- + Easy Home definition
- + On-Machine Verification
- + Tool Presetter support
- + Easy geometry selection on solid model
- + Supports a wide range of probe cycles
- + Visualization of all the Probe tool movements
- + Support of different Probe controllers

Combined Probe and Machining Operations

Machining operations and Probe operations are inter-mixed in the SolidCAM CAM manager and can use the same geometries on the solid CAD model. When the solid model is changed, both the machining and probe operations can be automatically synchronized to the change.

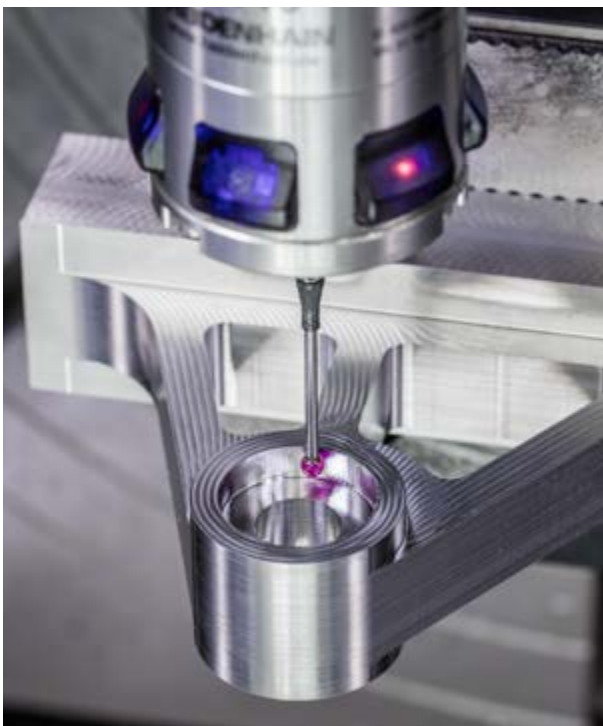



Home Definition

Solid Probe provides an easy solution for home setting, using 16 different cycles, to easily define home positions, replacing manual setup procedures.

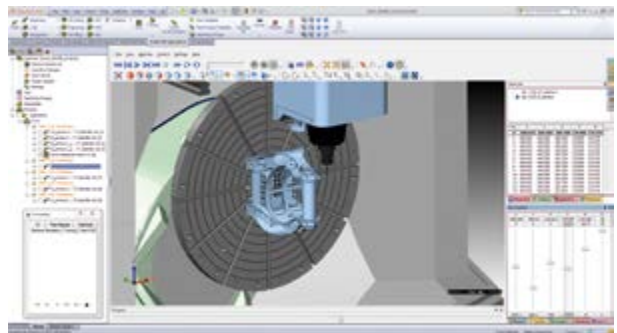

On-Machine Verification

Solid Probe cycles are used for measuring machined surfaces, without transferring the part to a CMM machine – the part can be inspected on the machine tool itself.

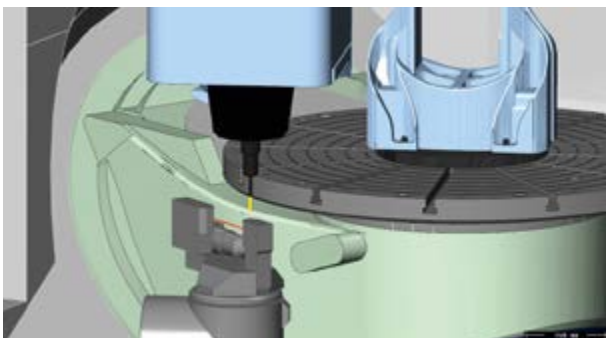

Tool Presetter Support

Solid Probe includes Tool Presetter support to check your milling and turning tools between Machining operations and tool change events. It also provides tool breakage detection to ensure continuous and safe machining.

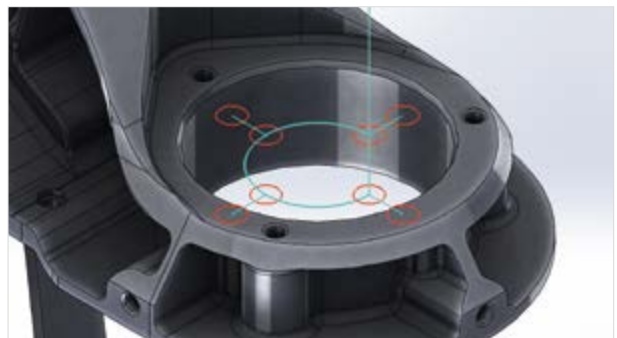

Preview of Cycle Movements

Solid Probe uses the same geometry as the 2.5D milling operations. Full control over tolerances, different sorting options and direct preview of cycle movements are provided.

About SolidCAM

SolidCAM – The Leaders in Integrated CAM

Founded 1984, SolidCAM has over 30 years of expertise in CAM development and applications.

The integration strategy of SolidCAM in the major 3D mainstream CAD systems, SOLIDWORKS and Inventor, has created major growth and established SolidCAM as the leaders in Integrated CAM.

SolidCAM has the Certified Gold-Product status from SOLIDWORKS since 2003 and provides seamless, single-window integration and full associativity to the SOLIDWORKS design model.



InventorCAM has the Autodesk Certified Product status and provides seamless, single-window integration and full associativity to the Inventor design model.

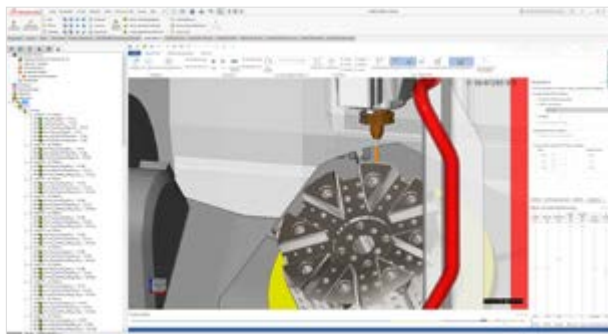

Our Advantages

➤ Providing a powerful, easy-to-use, complete, integrated CAD/CAM solution that supports the complete range of major manufacturing applications including iMachining 2D, iMachining 3D, 2.5D Milling, High Speed Surface Milling, 3D Milling/High-Speed Machining, Multi-Sided Indexial 4/5-Axes Milling, Simultaneous 5-Axes Milling, Turning, Advanced Mill-Turn and Solid Probe.

➤ SolidCAM's unique, revolutionary iMachining technology saves 70% in CNC machining time & more and extends tool life dramatically.

➤ The iMachining Technology Wizard provides a reliable partner in automatically determining speeds and feeds and other machining parameters.



➤ iMachining provides unbelievable savings and increased efficiency in your milling CNC operations, translating into profits and success. All SolidCAM customers worldwide, who bought iMachining, are enjoying immense savings!



TIME SAVINGS
70%
... AND MORE!



Our Sales & Support Network

Along with our worldwide direct sales and support teams from our many international SolidCAM offices, SolidCAM has a worldwide CAM distributor network in 50 countries, providing the best technical support and post-processor customization.

Our Customers

SolidCAM's large user base, with more than 20,000 seats, includes customers in the mechanical manufacturing, electronics, medical, consumer products, machine design, automotive and aerospace industries, and in mold, tool & die and rapid prototyping shops.

SolidCAM customers include small Job Shops, medium-size Engineering and Manufacturing companies, large Aerospace and Automotive companies and technical education institutions.

SolidCAM on Facebook



Join our Facebook page for daily posts in your News Feed about SolidCAM News, iMachining Success Stories, SolidCAM Professor Recordings, Upcoming Webinars, Events and Product releases.

www.facebook.com/SolidCAM

SolidCAM Professor

Our SolidCAM professor videos provide hundreds of easy to follow, tightly focused on a specific function, tutorial videos available 24 hours a day, 365 days a year, right on our website.

www.solidcam.com/professor

SolidCAM University Webinars

SolidCAM University regularly runs webinars for our partners, customers and potential customers. We invite you to join one of our upcoming SolidCAM webinars. During our webinar demonstration you can interact directly with the presenter and have your questions answered.

www.solidcam.com/cam-webinars

SolidCAM on YouTube



See powerful cutting videos of SolidCAM & iMachining on our SolidCAM iMachining YouTube channel.

www.youtube.com/SolidCAMiMachining



SolidCAM CNC Technology Centers

*The Perfect Place to Demonstrate the Power of
SolidCAM Software with Live Cutting*

SolidCAM GmbH Technology Centers in Germany

Our major technology center is located at the SolidCAM GmbH office in Schramberg, Germany. In addition we maintain technology centers in the south and east of Germany. All our Milling, Turning and Mill-Turn technologies are thoroughly checked and can be demonstrated live on our latest CNC machines:

- + Hermle C30 5-Axis CNC with Heidenhain controller
- + DMG NTX 1000 Mill-Turn Machine with Upper B-Axis, Lower Turret and Sub-Spindle, Siemens controller
- + Citizen L20 sliding headstock automatic lathe
- + Alzmetall GS 800/5-FDT, Siemens 840 controller, 5-X Milling and Mill-Turn Center
- + Quaser MF400 Milling 5X-Milling center, Heidenhain 530 Controller

SolidCAM customers, resellers and participants of our trainings all benefit from this practical experience.



TC Rosenheim



TC Suhl

Faster from the CAD model to the finished workpiece

We live this motto in our technology centers – day after day



SolidCAM USA Technology Center

The USA Technology Center is located at our SolidCAM Inc. offices in Newtown, Pennsylvania.

A HURCO VM10i CNC Machine is used to demonstrate the power of our Milling modules, enabling us to show customers all of the benefits of revolutionary iMachining, HSS, HSM, and more, in a shop floor style environment.

A classroom setting for our customers is located right next to the machine for practical training.



Perfect Testing for Our Latest Technologies

Our latest technologies are tested and proven out in-house at our worldwide technology centers. Customers benefit from practical CNC training along with software training.



Join Our LIVE Cutting Webinars from our Technology Centers

Attend our Live-Cutting webinar events to see live the power of iMachining 2D & 3D and our advanced Mill-Turn. Visit our website to register for these webinars.



CERTIFIED
Gold
Product

SOLIDWORKS



SolidCAM

iMachining – The Revolution in CAM!

SolidCAM GmbH

Gewerbepark H.A.U. 36
DE-78713 Schramberg
E-Mail: info@solidcam.de
Phone: +49 7422 2494-0

Sales Office

DE-78658 Zimmern

South

DE-83026 Rosenheim

North

DE-48477 Hörstel

East

DE-98527 Suhl-Friedberg

West

DE-74889 Sinsheim

South East

DE-92318 Neumarkt

North West

DE-57072 Siegen

SolidCAM Inc.

E-Mail: infonorthamerica@solidcam.com
Phone: +1 866 975 1115

SolidCAM Ltd.

E-Mail: info@solidcam.com
Phone: +972 3 5333 150

SolidCAM UK

E-Mail: info@solidcamuk.com
Phone: +44 1226 241744

SolidCAM France

E-Mail: info@solidcam.fr
Phone: +33 3 4457 1385

SolidCAM Ibérica, SL

E-Mail: info@solidcam.es
Phone: +34 635 201076

SolidCAM CZ

E-Mail: ivan.cimr@solidcam.cz
Phone: +420 603 893 701

SolidCAM India

E-Mail: info.india@solidcam.com
Phone: +91 80 26678933

SolidCAM China

E-Mail: marketing.china@solidcam.com
Phone: +86 10 8599 7302

SolidCAM Japan K.K.

E-Mail: info.japan@solidcam.com
Phone: +81 3 6300 6730

SolidCAM ANZ

E-Mail: info@solidcam.com.au
Phone: +61 400 622 133

SolidCAM Singapore Pte Ltd

E-Mail: snges@solidcam.com.sg
Phone: +65 9737 8116



www.facebook.com/SolidCAM



www.youtube.com/SolidCAMProfessor
www.youtube.com/SolidCAMiMachining

www.solidcam.com